

DEVELOPMENT OF JEEPINE

晶品发展历程

• 2008

晶品成立
Establishment of Jeepine



• 2009

第一代24腔压盖机，
单线产量最高20,000个/小时
1st generation 24 cavity CCM,
capacity was up to 20,000pcs/h

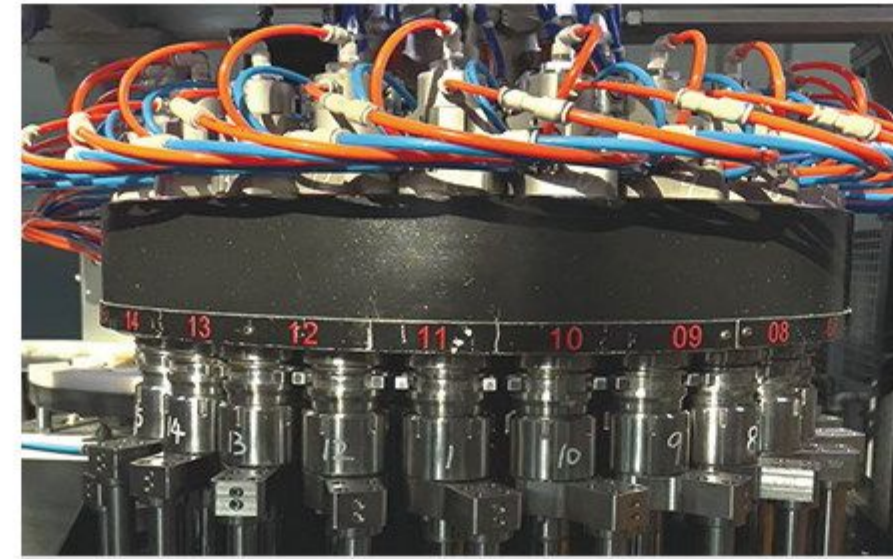

• 2012

第一代36腔压盖机
1st generation 36 cavity CCM

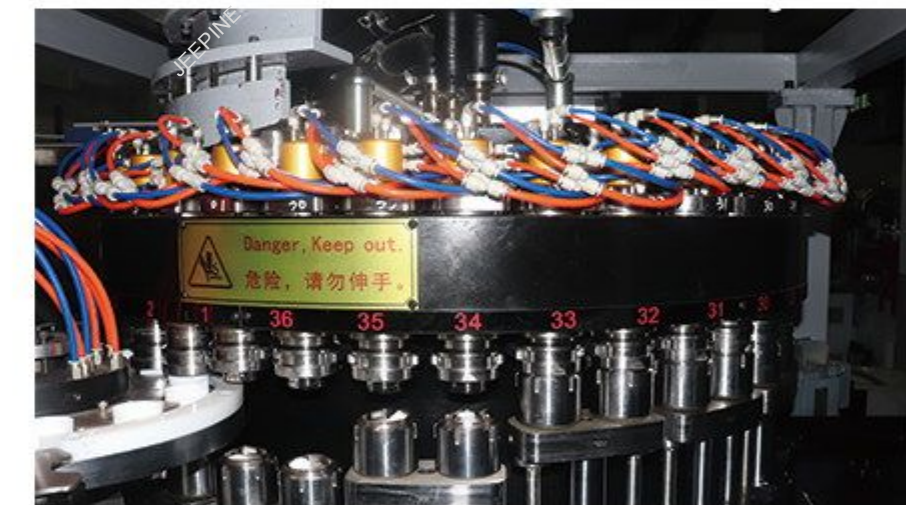

• 2015

挂牌新三板，
进入东南亚市场
Listed on NEEQ stock market.
Entered Southeast Asian market



• 2016

被列入国家首台套
重大装备应用目录，
进入印度及周边市场
Listed in National First Major
Equipment Guidance Listing.
Entered India and surrounding markets



• 2018

成功研制投产48腔压盖机
YSZG48, 进入欧美市场
Successfully developed and
produced CCM-YSZG48.
Entered European and American market

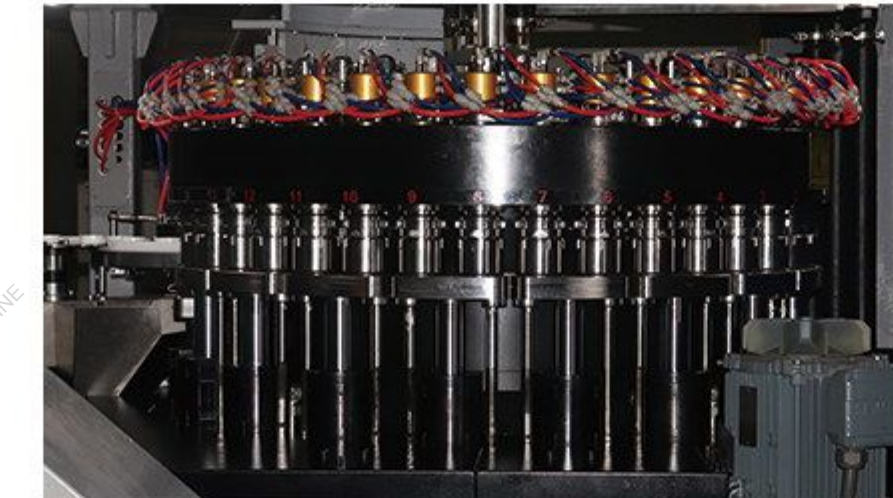

• 2019

累计获得120项
核心技术专利
Obtained 120 core technology
patents accumulatively



• 2020

成为金富，元气森林
战略合作伙伴
Become strategic partner
of Jinfu Technology, Chi Forest



• 2025

敬请期待...
Coming soon

• 2024

全球范围内晶品压盖机生产线保有量超过700条
More than 700 Jeepine CCM production lines are in
operation worldwide

700+ ↑

• 2023

与娃哈哈、银鹭等驰名品牌成为战略合作伙伴，
成功研发连体盖
Supply to Wahaha, Yinlu and other well-known brands.
Developed tethered caps



• 2022

成为健力宝，椰树战略合作伙伴，
进入俄罗斯市场
Become strategic partner of Jianlibao,
Coconut palm. Entered Russian market



• 2021

成功研制投产54腔压盖机YSZG54，
实现最高产量10万个/小时
Successfully developed and
produced CCM-YSZG54,
capacity was up to 100,000pcs/h



TURN KEY SOLUTION

整体解决方案

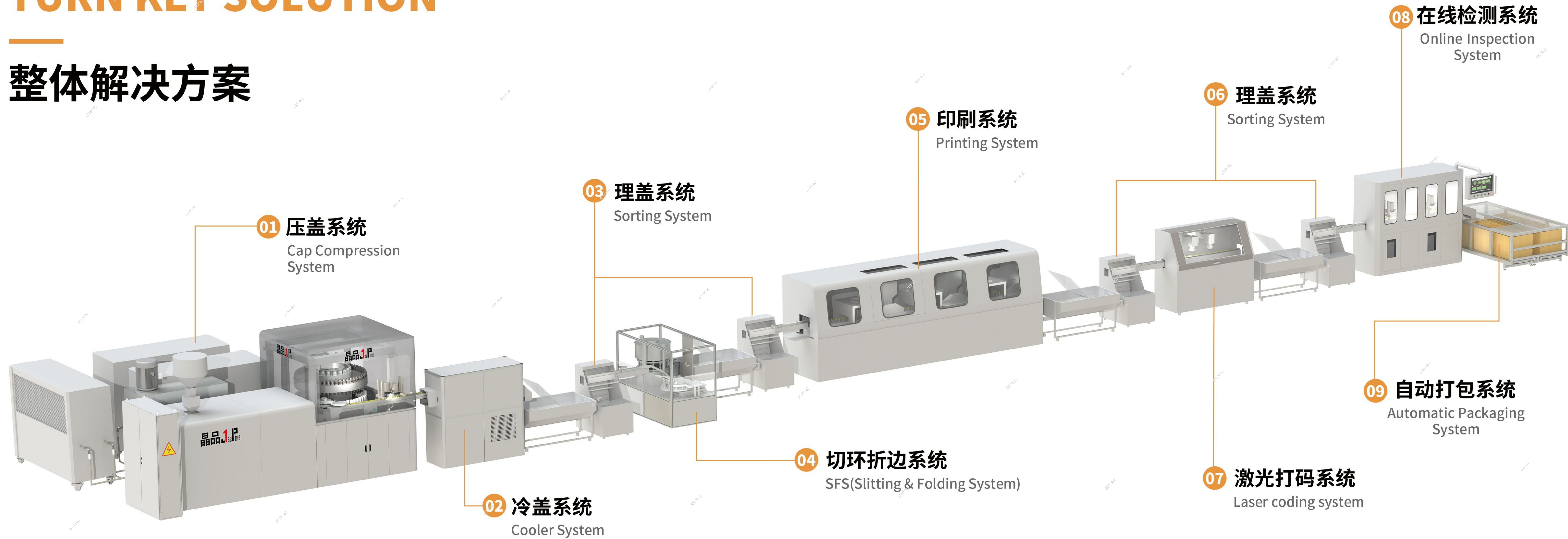

可选项 OPTIONAL

- 独立式供冷系统
Individual cooling system
- 集中式供冷系统
Integrated cooling system

- 独立式供料系统
Individual feeding system
- 集中式供料系统
Integrated feeding system

- 独立式切环折边系统
Individual SFS
- 集中式切环折边系统
Integrated SFS

- 胶印系统
Offset printing system
- 数码印刷系统
Digital printing system
- 混合印刷系统
Hybrid printing system

- 激光打码系统
Laser coding system
- 喷码系统
Inkjet coding system

- 单镜头视检系统
Single camera vision inspection
- 双镜头视检系统
Double cameras vision inspection
- 七镜头视检系统
Seven cameras vision inspection

- 自动打包系统
Automatic packing system

- 其他配置
Others

- 其他印刷系统
Others

- 其它多镜头视检系统
Others

PLASTIC CAPS SOLUTION

塑料瓶盖解决方案

盖型 Cap Types	瓶盖原料 Cap Material	瓶口规格 Neck Finishes Size	密封结构 Seal Structure	克重 Weight	应用 Application	防盗环种类 Band Type
 2622含气盖 2622 CSD CAP	HDPE	26mm	内塞+外塞 Inner plug + Outer plug	1.7g	碳酸饮料 Carbonated beverage	带排水孔的连接襟翼 Linked flaps with drainage holes
 2622水盖/无菌盖 2622 WATER/CAF CAP	HDPE	26mm	内塞+外塞 Inner plug + Outer plug	1.2g	纯净水、矿泉水等静态水 Purified water, mineral water and other static water	带排水孔的连接襟翼 Linked flaps with drainage holes
 2722水盖/无菌盖 2722 WATER/CAF CAP	HDPE	27mm	内塞+外塞 Inner plug + Outer plug	1.4g	纯净水、矿泉水等静态水 Purified water, mineral water and other static water	带排水孔的连接襟翼 Linked flaps with drainage holes
 2925水盖 2925 WATER CAP	HDPE	29mm	内塞+外塞 Inner plug + Outer plug	1.3g	纯净水、矿泉水等静态水 Purified water, mineral water and other static water	非折边卡扣式结构 No folding hook
 3025水盖 3025 WATER CAP	HDPE	30mm	内塞+外塞 Inner plug + Outer plug	1.9g	纯净水、矿泉水等静态水 Purified water, mineral water and other static water	非折边卡扣式结构 No folding hook
 1881含气盖 1881 CSD CAP	HDPE	28mm	内塞+外塞 Inner plug + Outer plug	2.3g	碳酸饮料 Carbonated beverage	带排水孔的连接襟翼 Linked flaps with drainage holes
 1881 无菌盖 1881 CAF CAP	HDPE	28mm	内塞+外塞 Inner plug + Outer plug	2.15g	水/果汁/奶制品/ 功能饮料/茶饮料等 Water, juice, dairy product, energy drink, tea drink, etc	带排水孔的连接襟翼 Linked flaps with drainage holes
 1810热灌装盖 1810 HOT FILLING CAP	HDPE	28mm	内塞+外塞 Inner plug + Outer plug	2.8g	水/果汁/奶制品/ 功能饮料/茶饮料等 Water, juice, dairy product, energy drink, tea drink, etc	带排水孔的连接襟翼 Linked flaps with drainage holes
 1810水盖 1810 WATER CAP	HDPE	28mm	内塞+外塞 Inner plug + Outer plug	2.8g	水/果汁/奶制品/ 功能饮料/茶饮料等 Water, juice, dairy product, energy drink, tea drink, etc	带排水孔的连接襟翼 Linked flaps with drainage holes

盖型 CAP TYPES	瓶盖原料 Cap Material	瓶口规格 Neck Finishes Size	密封结构 Seal Structure	克重 Weight	应用 Application	防盗环种类 Band Type
 28mm药盖 28MM MEDICAL CAP	HDPE	28mm	内塞+外塞 Inner plug + Outer plug	2.4g	医药用品等 Medical supplies etc	非折边卡扣式结构 No folding hook
 38mm无菌盖 38MM CAF CAP	HDPE	38mm	内塞+外塞 Inner plug + Outer plug	2.6g	果汁/奶制品/ 功能饮料/茶饮料等 Juice, dairy product, energy drink, tea drink, etc	带排水孔的连接襟翼 Linked flaps with drainage holes
 38mm无菌盖 38MM CAF CAP	HDPE	38mm	内塞+外塞 Inner plug + Outer plug	3.5g	果汁/奶制品/ 功能饮料/茶饮料等 Juice, dairy product, energy drink, tea drink, etc	带排水孔的连接襟翼 Linked flaps with drainage holes
 38mm聪明盖 38MM SMART CAP	HDPE	38mm	内塞+外塞 Inner plug + Outer plug	3.5g	纯净水、矿泉水等静态水 Purified water, mineral water and other static water	非折边卡扣式结构 No folding hook
 38mm组合盖 38MM COMBINATION CAP	HDPE	38mm	内塞 Inner plug	5.0g	医药用品等 Medical supplies etc	非折边卡扣式结构 No folding hook
 46mm瓶盖 46MM CAP	HDPE	48mm	内塞+外塞 Inner plug + Outer plug	4.6g	果汁/奶制品/ 功能饮料/茶饮料等 Juice, dairy product, energy drink, tea drink, etc	非折边卡扣式结构 No folding hook
 48mm聪明盖 48MM SMART CAP	HDPE	45mm	内塞+外塞 Inner plug + Outer plug	6.8g	4L/5L/8L/12L大桶水等 4L/5L/8L/12L barreled water, etc	非折边卡扣式结构 No folding hook
 54mm机油盖 54MM ENGINE OIL CAP	HDPE	50mm	内塞+外塞 Inner plug + Outer plug	6.0g	化工/机油/润滑油/ 日化用品等 Machine oil, daily chemical products, etc	非折边卡扣式结构 No folding hook
 55mm聪明盖 55MM SMART CAP	HDPE	55mm	内塞+外塞 Inner plug + outer plug	6.9g	5L/8L/12L大桶水等 5L/8L/12L barreled water, etc	非折边卡扣式结构 No folding hook
 白酒内盖 LIQUEUR INNER CAP	HDPE	18mm	内塞 Inner plug	0.6g	白酒 Liqueur	带排水孔的连接襟翼 Linked flaps with drainage holes
 牙膏盖 TOOTHPASTE CAP	HDPE	10mm	内塞+外塞 Inner plug + Outer plug	1.3g	日化用品等 Chemicals, etc	带排水孔的连接襟翼 Linked flaps with drainage holes

MODEL INTRODUCTION

机型介绍

型号 Model	YSZG54	YSZG48A	YSZG48B	YSZG24	CCM-JP24D
每小时最大产量 Max production capacity (pcs/hr)	100000	80000	75000	40000	24000
模腔数 Number of cavities	54	48	48	24	24
原材料 Raw material	HDPE/PP	HDPE/PP	HDPE/PP	HDPE/PP	HDPE/PP
瓶盖最大外径 Max. outer dia.	35mm	35mm	45mm	55mm	55mm
瓶盖最大标称高度 Max. height	25mm	25mm	25mm	25mm	30mm
瓶盖最大标称重量 Max.weight	4g	4g	6.5g	7.5g	7.5g
每小时耗电量 Power consumption (kw/hr)	122±5	116±5	116±5	83±5	65±5

注 (Remark):

1. 其他盖型以实际评估为准 Other cap types are subject to actual assessment
2. 以上产能为HDPE, PP料产能以实际为准 The above production capacity is for HDPE material, production capacity of PP material is subject to actual condition

MACHINE ADVANTAGES

设备优势

01 稳定 Stable

整体式转盘设计, 高精度双泵液压系统, PID运算控制低压合模高压成型运行过程稳定

Integrated rotary forming unit, high precision double pumps hydraulic system, PID operation control low pressure closing and high pressure forming

02 高速 Efficient

新型高速送料系统, 多模连续高速旋转, 真空吸附式出盖, 生产效率高

New type high speed feeding system, multi-mould continuous high speed rotary forming. Vacuum absorption cap making with high production efficiency

03 节能 Energy Saving

聚合物低温熔融, 加热、冷却能耗低。

Low temperature heating for polymer melting, low power consumption in heating and cooling process

04 省材 Material Saving

智能温控挤出, 料丸定量切割, 克重稳定, 原材料充分利用

Quantitative pellet cutting, consistent and stable weight, raw material is fully utilized

05 安全 Safe

智能化逻辑控制系统, 自动监视、报警, 自动诊断、自动保护

Intelligent logic control system, automatic monitoring and alarm automatic diagnosis and protection

06 卫生 Clean

可实现盖、吹、灌、旋一体化方案, 在线制盖、连线输送, 洁净卫生

Cap production can be integrated in blowing-filling-capping line, on-line cap production, on-line transportation

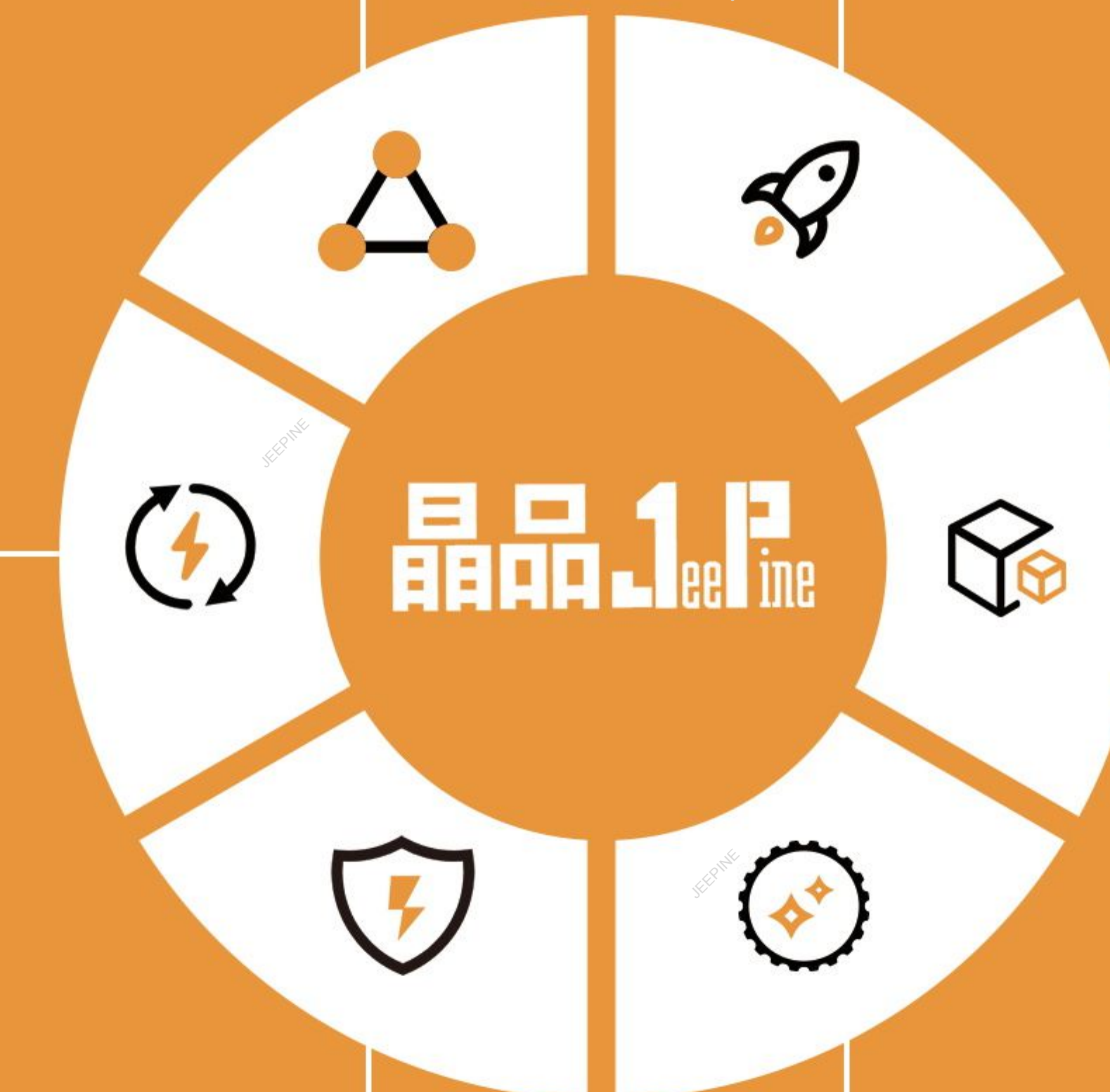

MOLD ADVANTAGES

模具优势

01 高品质 HIGH QUALITY

进口材料：合金模具材料，导热性能好、强度高、耐磨性好
热处理：经过回火、深冷等十多道工序。

Imported material: Alloy mould material with high thermal conductivity, high strength and high wear resisting. Heat treatment: More than ten steps including tempering, subzero treatment.

02 高精度 HIGH PRECISION

高精度模具，制盖尺寸公差小、合格率高。

High precision mould, small tolerance of cap dimension, high qualification rate.

03 高速度 HIGH SPEED

新型高速单冷、多流道冷却技术，冷却成型周期短。

High speed: new Multi-channel cooling technology shorten the cooling cycle significantly.

04 多样化 DIVERSIFICATION

多样化个性设计，快速满足各类盖型需求。

Diversified and personalized design, to meet the requirements of various kinds of cap types quickly.

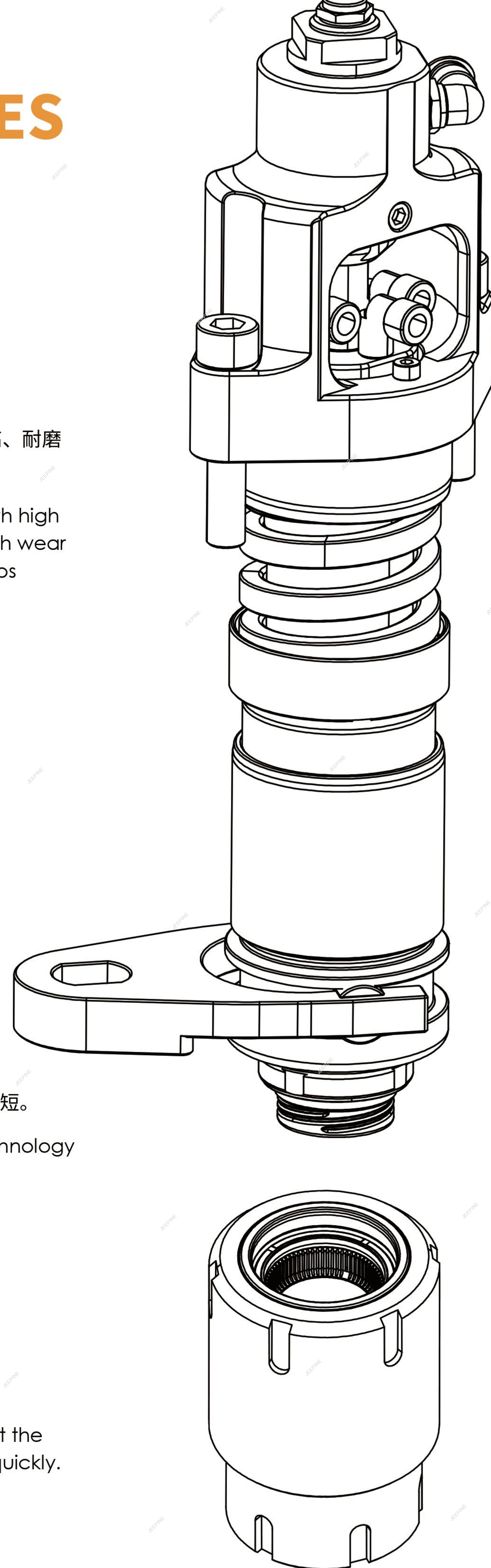

RANGE OF JEEPINE PLASTIC CAPS

晶品盖型一览

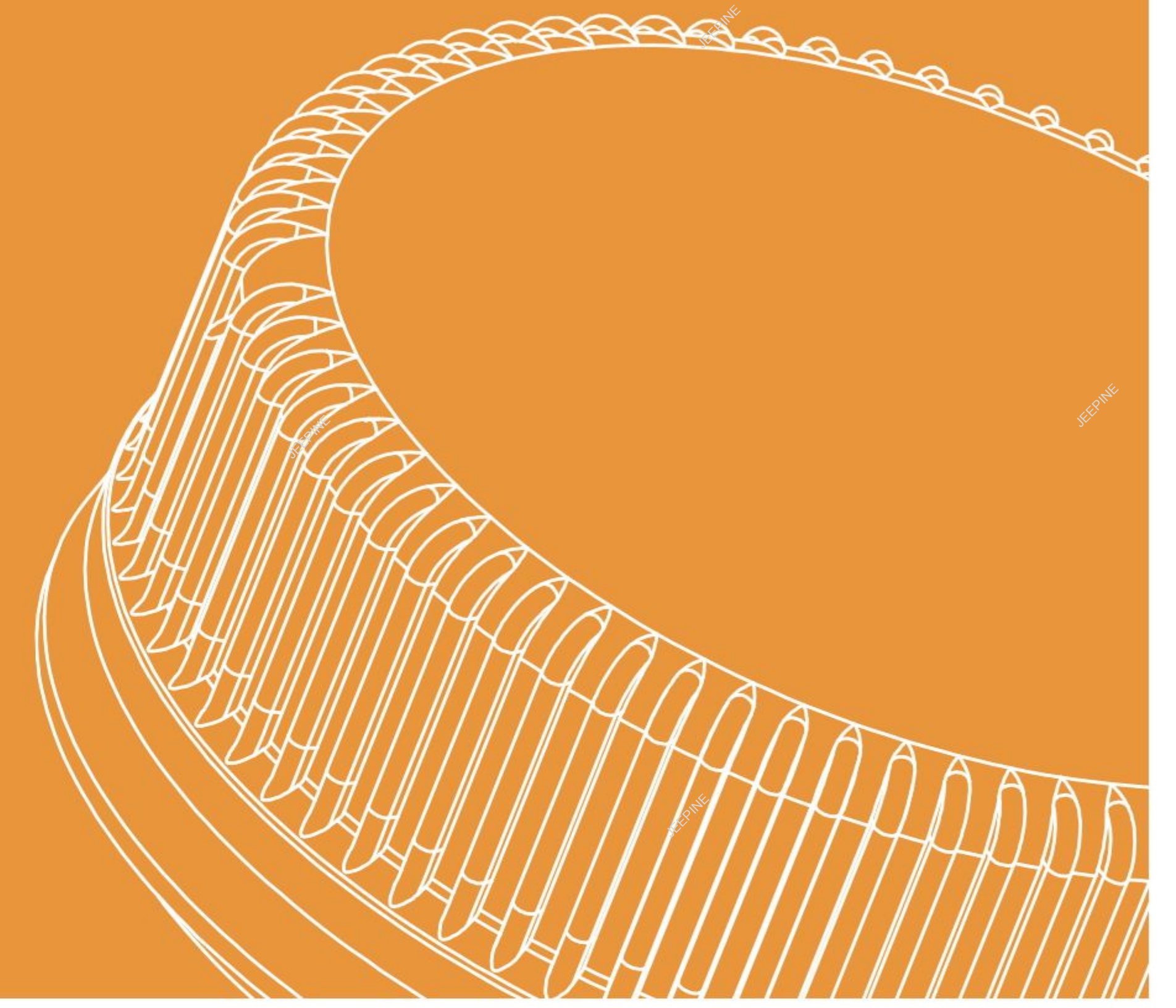

WATER CAPS
水盖



CAF CAPS
无菌盖

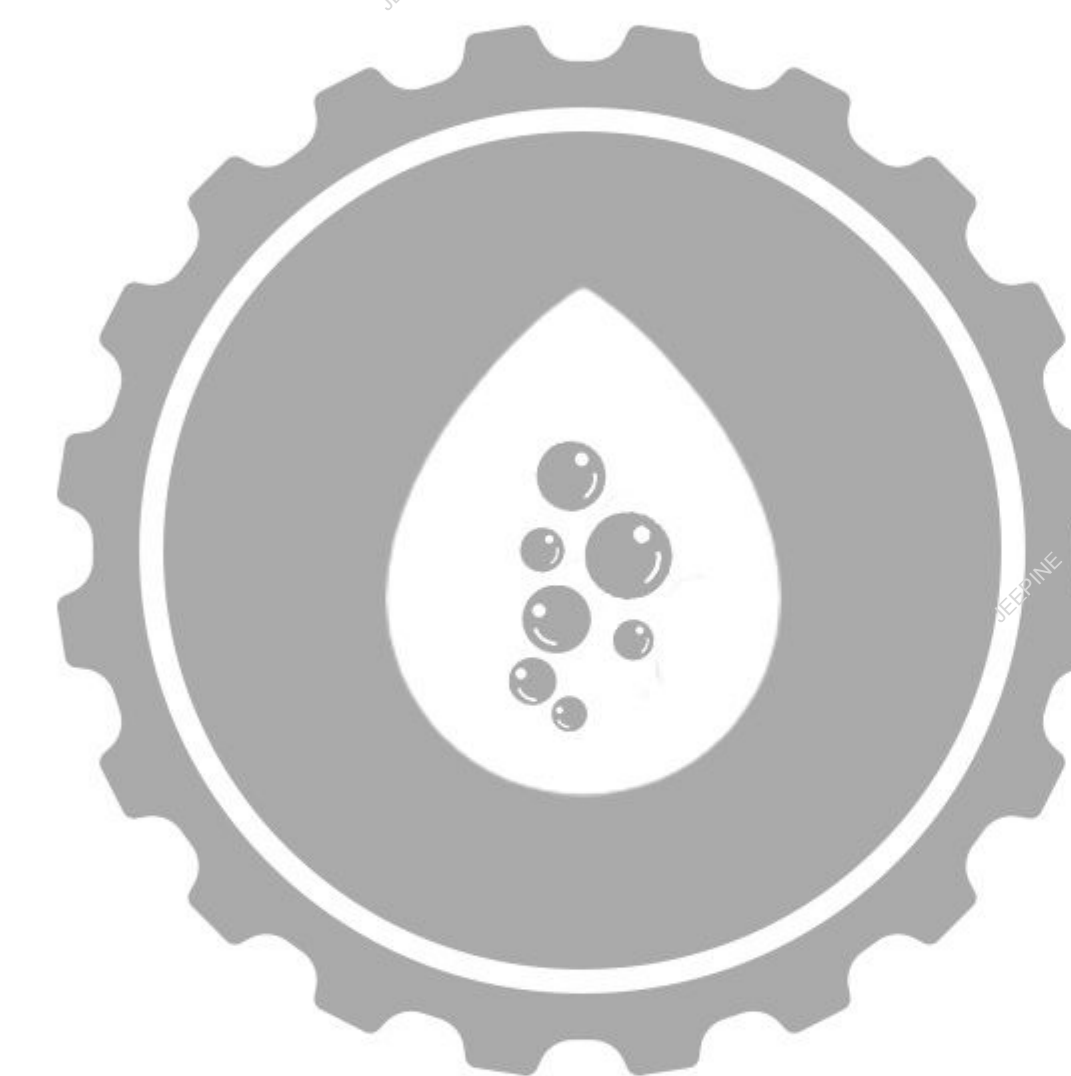

CSD CAPS
碳酸盖



HOT FILLING CAPS
热灌盖

TECHNOLOGY R&D CENTRE SERVICES

技术研发中心服务

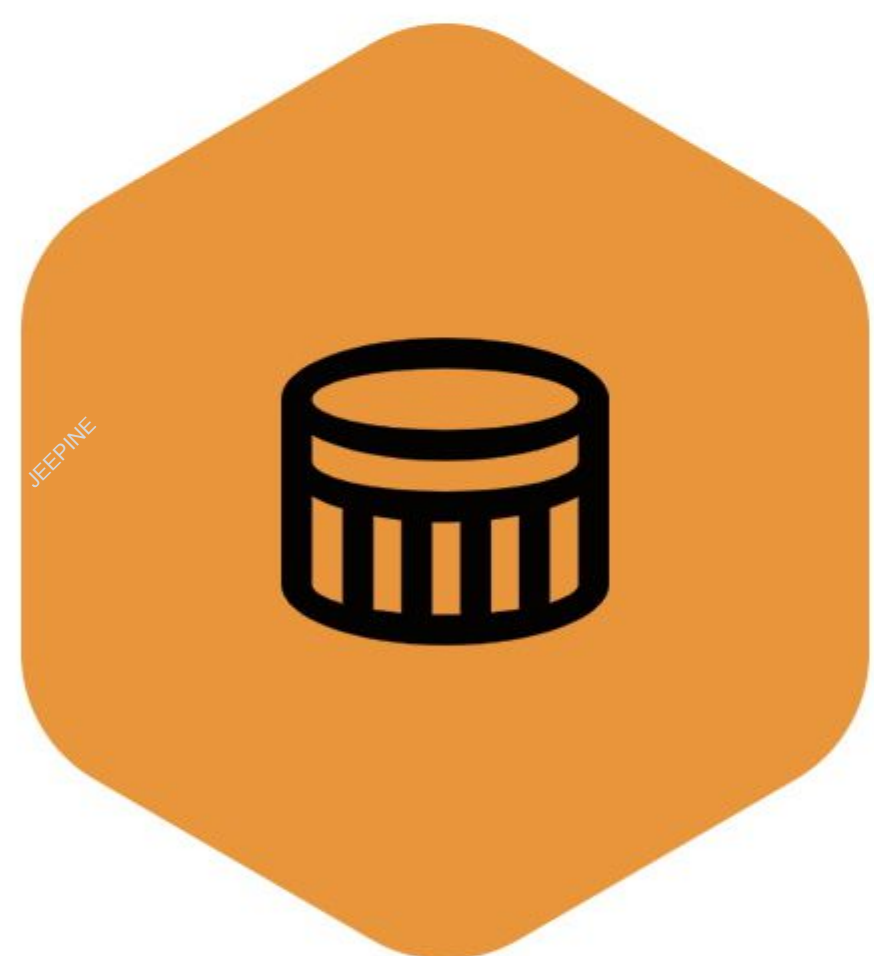
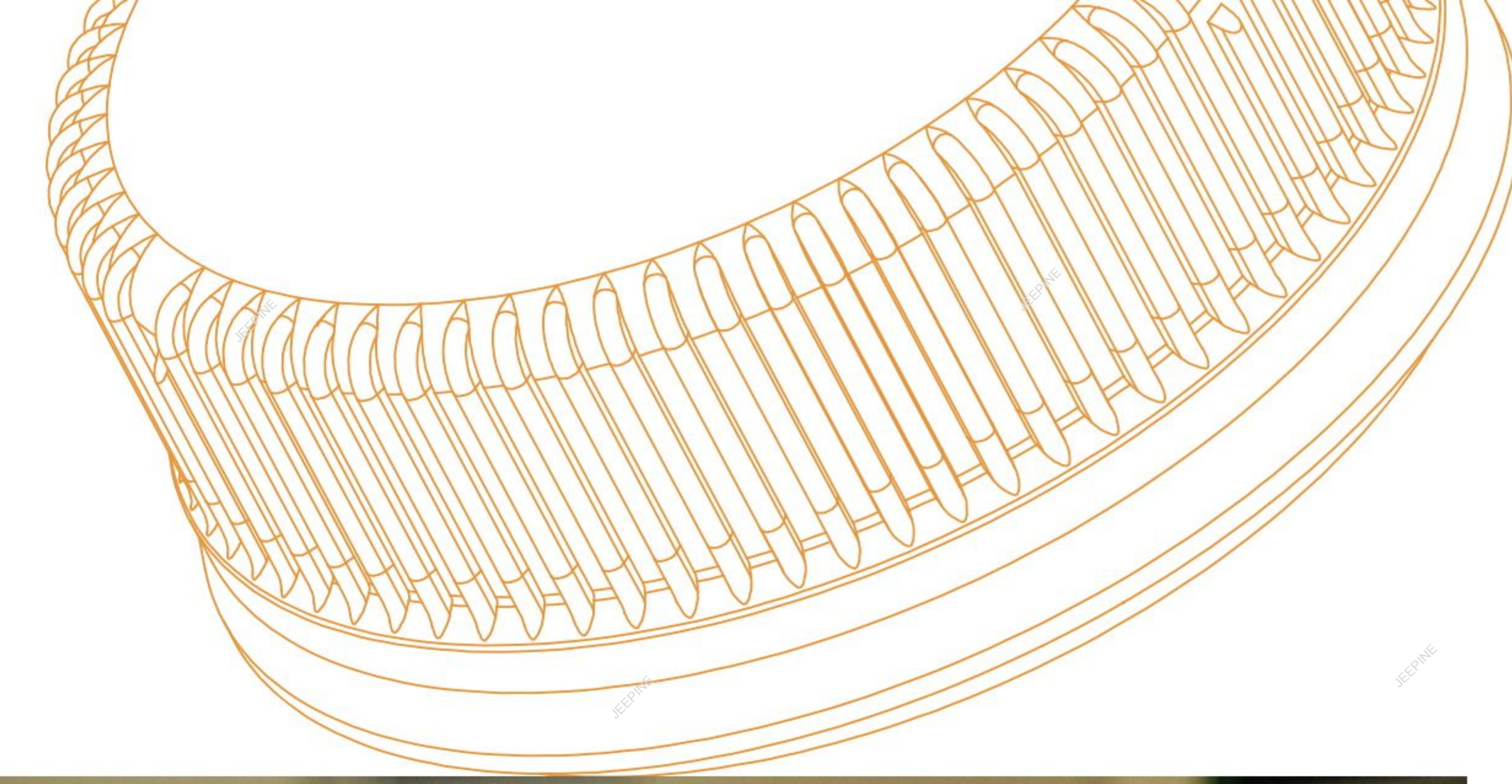

专属瓶盖设计
Exclusive
Cap Design



实验模开发打样
Testing Mold
Development & Proofing



瓶盖检测评估
Caps
Assessment

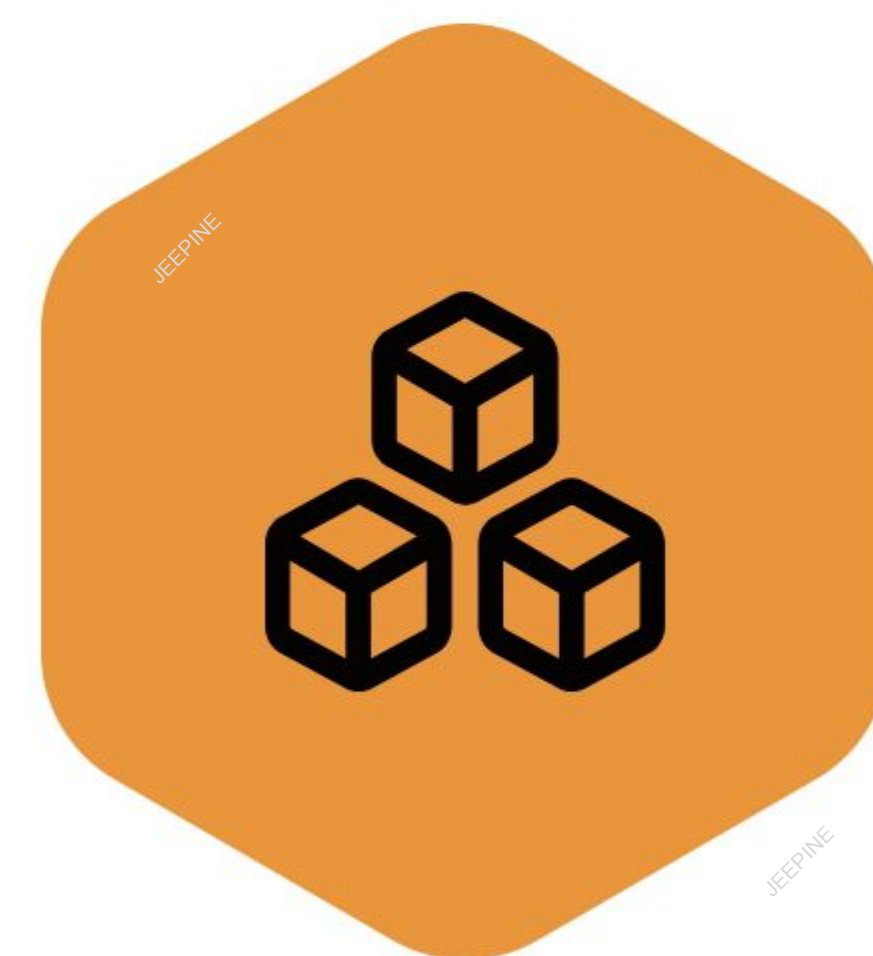

原材料测试
Raw Material
Testing



瓶盖试线跟踪
Caps Application
Testing & Tracking



厂房规划设计
Factory
Planning & Design

APPLICATION

应用



饮用水
Drinking Water



饮料
Beverages



酒类
Alcoholic Products



乳制品
Dairy Products



日化用品
Daily Chemical Products



医药用品
Medical Supplies

合作伙伴 PARTNERS



排名不分先后，更多信息请咨询您的销售经理。
In random order with no particular order. For more information, please consult your sales manager.

JEEPINE SERVICE IS AVAILABLE AT

晶品服务于

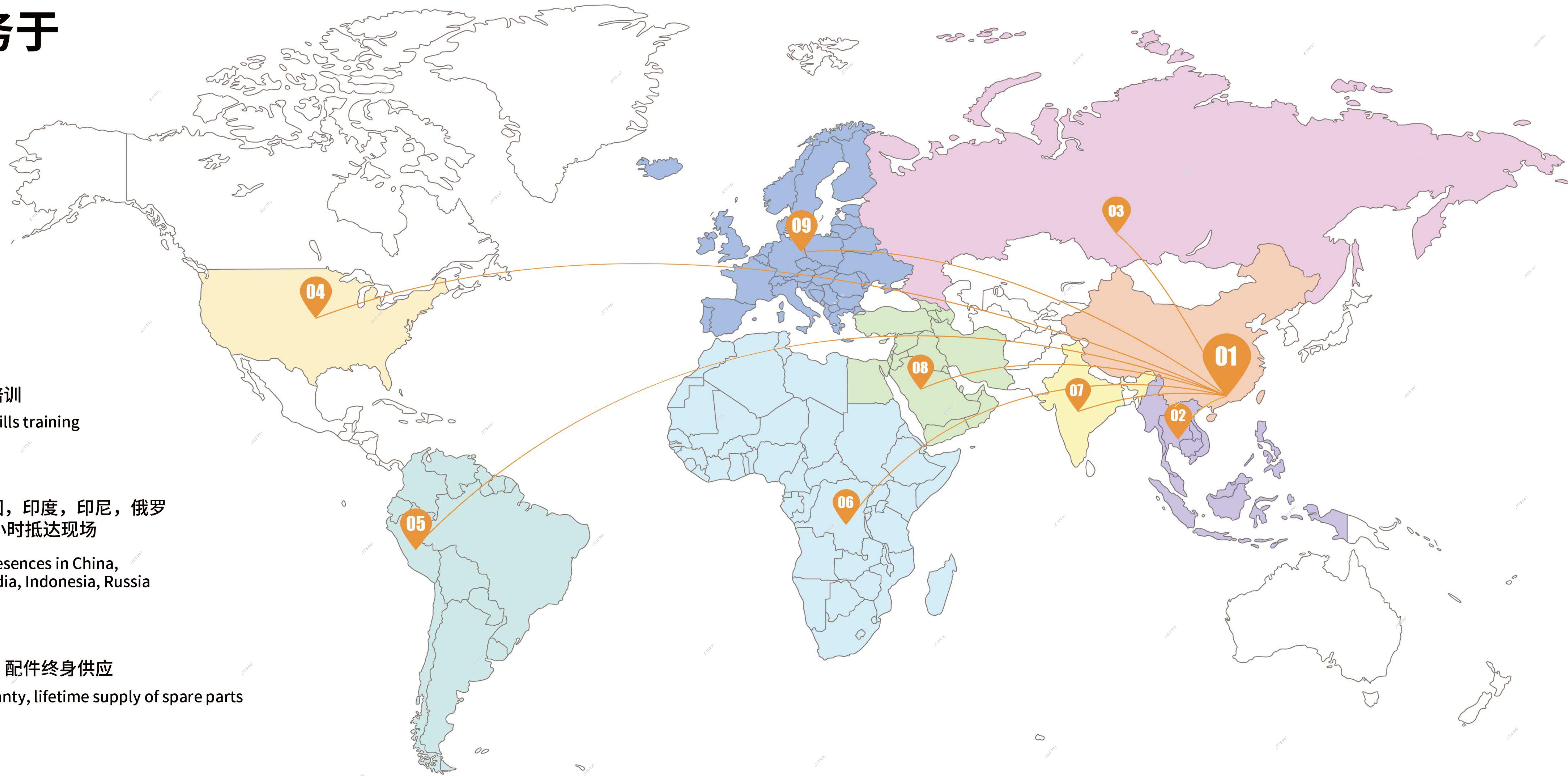

员工技能培训
Operator skills training



72h 中国, 美国, 印度, 印尼, 俄罗斯区域72小时抵达现场
72 hours presences in China, America, India, Indonesia, Russia



1year 保修一年, 配件终身供应
1 year warranty, lifetime supply of spare parts



定期巡检
Regular inspection



相同或更高等级设备可升级服务
Upgrade service available for same level or higher

- 01 中国- China
- 02 东南亚地区- Southeast Asia
- 03 俄罗斯- Russia
- 04 美国- United States
- 05 南美洲- South America
- 06 非洲- Africa
- 07 印度- India
- 08 中东地区- Middle East
- 09 欧洲地区- Europe



为客户创造价值

CREATING VALUE FOR CUSTOMERS

广州晶品智能压塑科技股份有限公司
Guangzhou Jeepine Intelligent Compression Molding Machine Co.,Ltd



微信公众号



抖音



Facebook



Youtube

证券代码
STOCK CODE
833127